

(No Model.)

4 Sheets—Sheet 1.

E. CHILDS.
LATHE.

No. 461,401.

Patented Oct. 13, 1891.

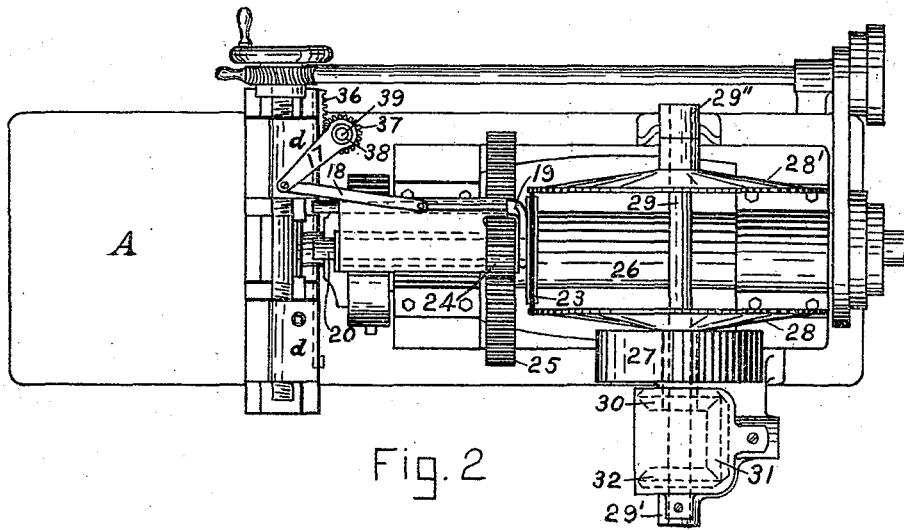
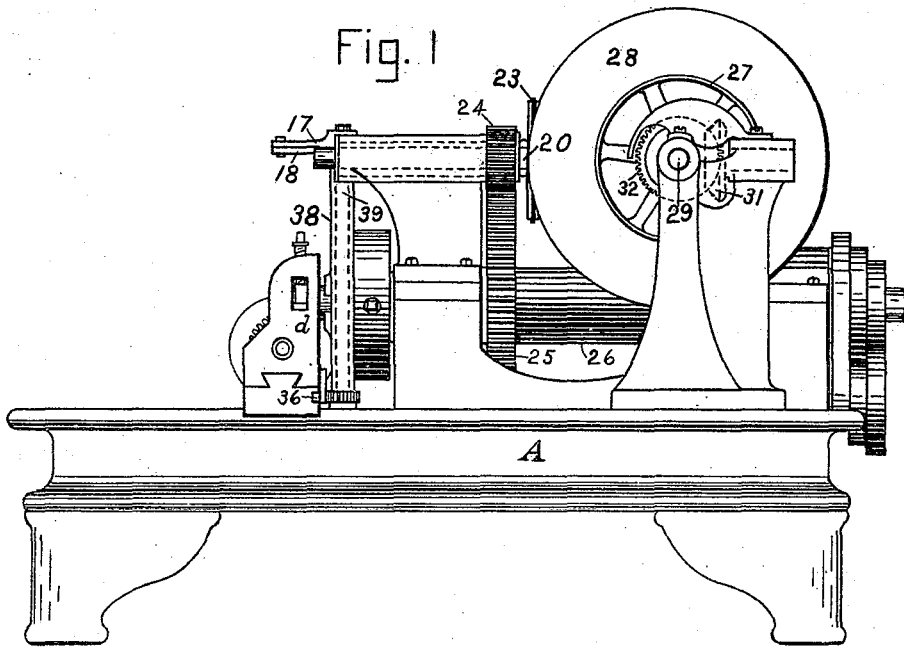

Witnesses:
J. D. F. Smith
J. H. Trague

Inventor:
Eugene Childs
By O. Noble atty

(No Model.)

4 Sheets—Sheet 2.

E. CHILDS.
LATHE.

No. 461,401.

Patented Oct. 13, 1891.

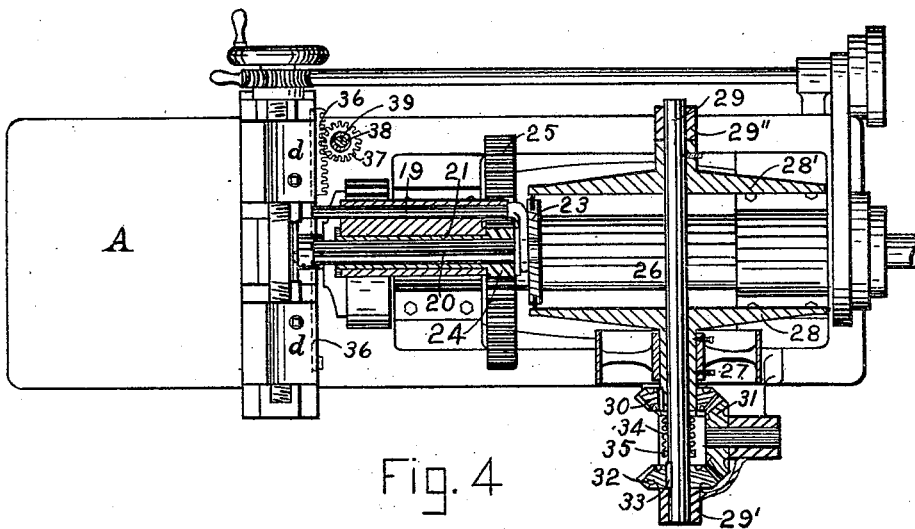
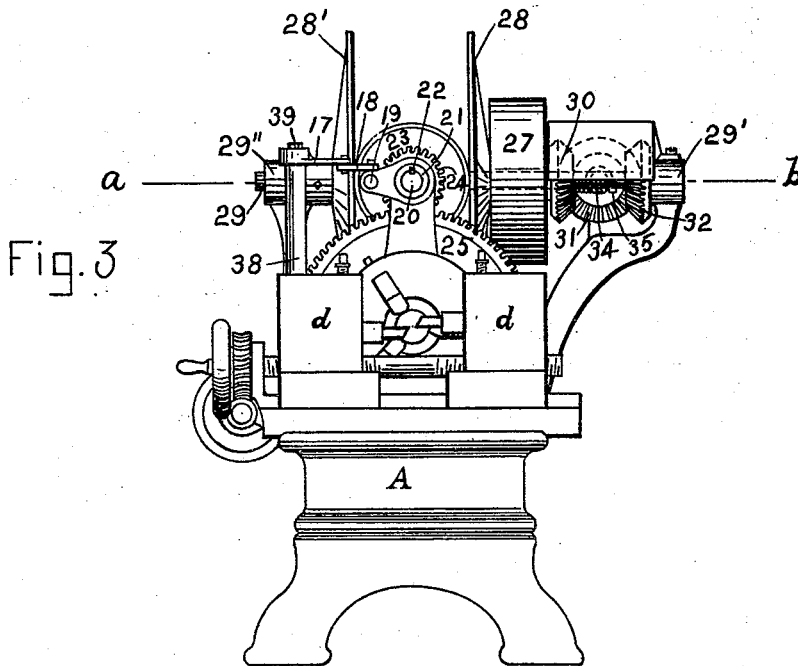

Witnesses:
J. W. F. Demuth.
J. C. Peague.

Inventor:
Eugene Childs
By A. Noble atty

(No Model.)

4 Sheets—Sheet 3.

E. CHILDS.
LATHE.

No. 461,401.

Patented Oct. 13, 1891.

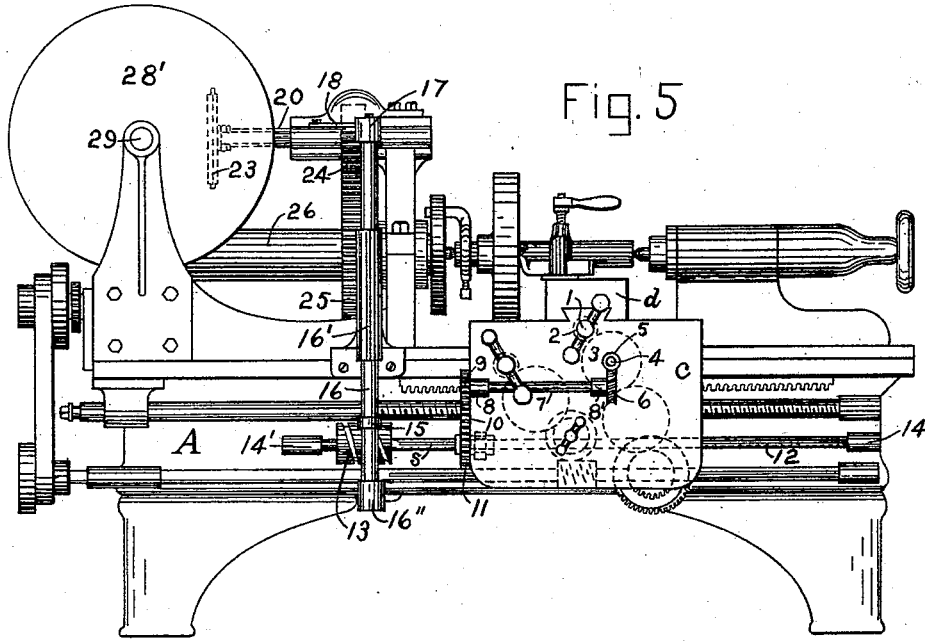

Fig. 5

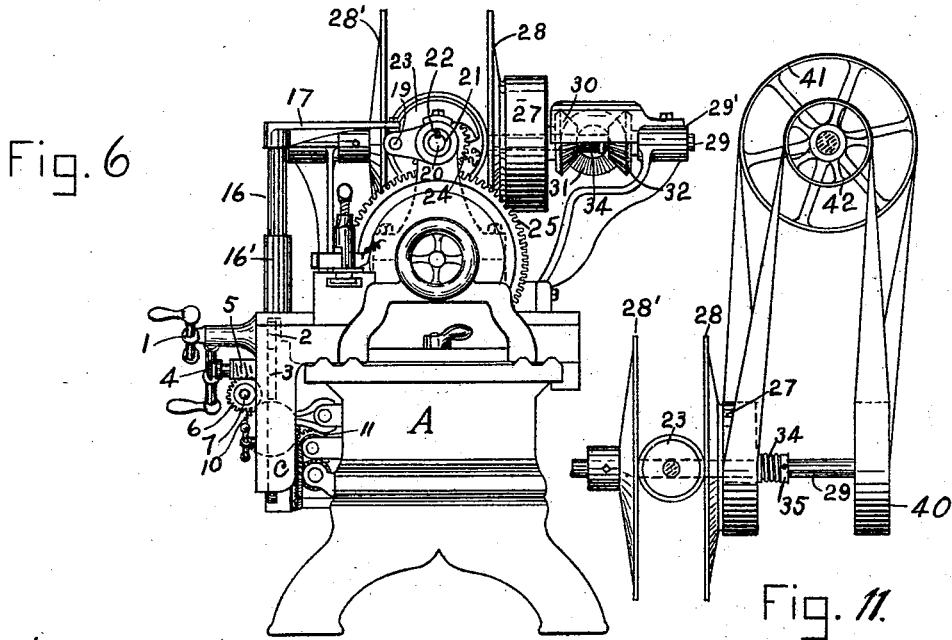

Fig. 6

Fig. 11

Witnesses:
J. W. F. Demuth
J. A. Deague

Inventor:
Eugene Childs
By J. K. Noble atty

E. CHILDS.
LATHE.

No. 461,401.

Patented Oct. 13, 1891.

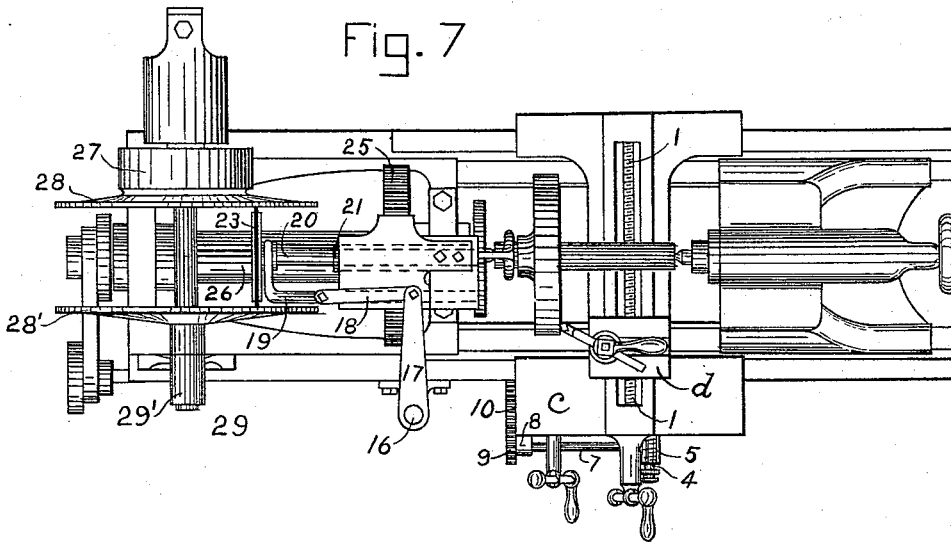

Fig. 7

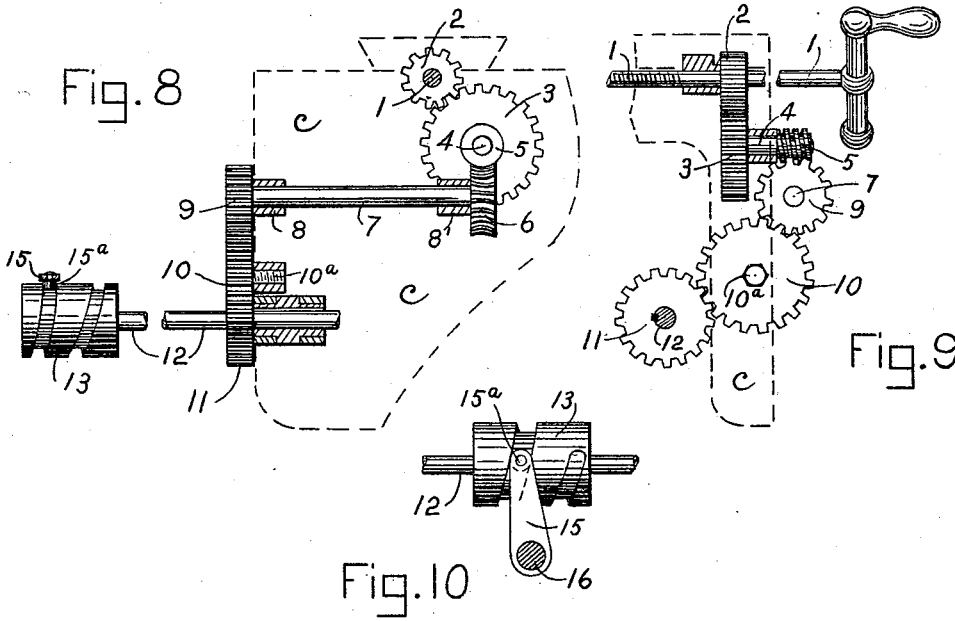

Fig. 8

Fig. 9

Fig. 10

Witnesses:
L. S. Goldthwait
Stephen Moore

Inventor:
Eugene Childs
By O. Noble atty

UNITED STATES PATENT OFFICE.

EUGENE CHILDS, OF BOSTON, MASSACHUSETTS, ASSIGNOR TO HIMSELF
AND OSCAR L. NOBLE, OF SAME PLACE.

LATHE.

SPECIFICATION forming part of Letters Patent No. 461,401, dated October 13, 1891.

Application filed February 2, 1891. Serial No. 379,943. (No model.)

To all whom it may concern:

Be it known that I, EUGENE CHILDS, of Boston, in the county of Suffolk and State of Massachusetts, have invented a new and useful Improvement in Lathes, of which the following, taken in connection with the accompanying drawings, is a specification.

My invention relates to certain improvements in that class of machines known as "lathes," "cut-off machines," or "screw-machines," wherein the well-known cross-feed or tool-carriage for advancing or withdrawing the tool in a plane at right angles to the central line of the lathe is used, and wherein the material to be cut is held by any of the well-known devices and rotated against the tool. Heretofore the speed of the rotating material has been changed as desired by the use of cone or step pulleys, the workman shifting the belt thereon to effect such change.

The object of my invention is to secure approximately uniform rotary speed of the material against the cutting-tool as it passes through the material from its largest to its smallest diameter, or vice versa, as in the case of certain work held by a chuck or face-plate, thereby insuring the largest product possible without depending upon the will of the workman, which result I obtain by a combination of devices attached to the cross-feed screw or tool-carriage and so connecting the latter by suitable mechanism to the spindle or head-stock of the machine that the desired result is obtained, as will more fully appear in the following description of a cut-off lathe and a common lathe embodying my invention.

Figure 1 is a side elevation of a cut-off lathe; Fig. 2, a plan view, Fig. 3 an end view, and Fig. 4 a section on line *a b* of Fig. 3, of the same. Fig. 5 is a side view, and Fig. 6 an end view, of a lathe, and Fig. 7 a plan of the same. Figs. 8 and 9 are front and end views, respectively, of the carriage *c* with portions cut away, so as to show the working parts. Fig. 10 is a plan view of the cam 13 and arm working therewith; Fig. 11, an arrangement of belts and pulleys instead of gears and pinions to effect the reverse rotary motion of the disks.

Like numbers and letters refer to corresponding parts in all the views.

Referring to the lathe shown in Figs. 5 to 10, inclusive, which has the usual parts of a common lathe—viz., a carriage, a cross-feed tool-carriage, a head-stock and spindle, all old and well known, but mentioned for reference—*A* is the bed or frame; *c*, the carriage; *d*, the cross-feed tool-carriage carrying the usual tool-post and tool, as shown. 1 is the cross-feed screw-threaded into the cross-feed carriage, having its bearing in carriage *c* and carrying pinion 2, which engages gear 3 on shaft 4, which has a worm 5, Figs. 6 and 9, cut on its outer end, which engages worm-gear 6, fastened to shaft 7, running in bearings 8 and 8', attached to carriage *c*, and having mounted on it gear 9, engaging intermediate gear 10, held on a stud 10^a in the end of carriage *c*, which in its turn engages gear 11, which has a key and is mounted on cam-rod 12, held in bearings 14 and 14' on the lathe-frame *A*, said cam-rod having a slot its whole length, in which the key of gear 11 is free to move, thus allowing the workman to move the carriage to any position without rotating the said cam-rod. 13 is a cam on cam-rod 12, the groove of which engages a stud-roll 15^a on arm 15, attached to vertical shaft 16, carried in bearings 16' and 16''. This shaft has an oscillating motion imparted to it by the cam 13, in which a roll 15^a on arm 15 runs. To the upper end of shaft 16 is attached arm 17, connected by link 18 to shipper rod and fork 19. The fork on the end of shipper-rod 19 spans the friction-wheel shaft 20, Fig. 7, and is fitted into a circumferential groove cut into the shaft to receive it. This shaft is carried in a sleeve 21 and drives said sleeve by a feather 22, Fig. 6, fitted loosely in the sleeve and fast to the shaft 20, allowing said shaft to move endwise and carry the friction-wheel 23 to and from the center of the friction-disks 28 and 28'. On this sleeve is cut or fastened a pinion 24, which engages gear 25, that is fastened to the head-stock spindle 26, to which the work is attached.

The foregoing is all driven by pulley 27, Fig. 6, attached to driving-disk 28, having miter-gear 30 attached and running loosely on shaft 29. Said miter-gear engages intermediate gear 31, which in turn drives miter-

gear 32, attached to shaft 29 by key 33, Fig. 4. Said shaft is carried in bearings 29' and 29'' and drives disk 28', attached thereto, this arrangement of gears causing the said driving-disks to rotate in opposite directions when power is applied to pulley 27. The disks 28 and 28' are held in contact with driving-wheel 23 by the compression of coil-spring 34 between collar 35 and the hub of gear 30. (Best shown in Fig. 4.)

For light work one disk, as 28', might be dispensed with, thus dispensing also with the bevel-gears 30, 31, and 32; but I prefer the arrangement shown, as it brings no lateral pressure on the bearings of shaft 20, as would be the case with the use of a single disk only.

In some kinds of lathes in which a longitudinal movement of the carriage is not required—notably for cutting off stock only—and which are frequently provided with two tool-carriages *d d*, operated by one and the same right and left hand screw, so as to be drawn toward and from each other and the center of the work by the same movement of the screw, I attach to one of said cross-feed carriages (in this case the rear one) a slide-rack 36, Figs. 2 and 4, engaging pinion 37 on lower end of sleeve 38, to the top of which is attached arm 17, said sleeve being held in place on stud 39, which is attached to the body of the machine, (shown by dotted line, Fig. 1,) and upon which the sleeve 38 is free to oscillate. It will be obvious that the office of sleeve 38 (shown in Figs. 1, 2, 3, and 4) and vertical shaft 16, Figs. 5 and 6, is the same, either being used as may be found most convenient in adapting my invention to different kinds of lathes.

Fig. 11 shows an arrangement of pulleys and belt whereby the reverse rotation of the disks is obtained, instead of by gears heretofore described, wherein a belt is passed over the pulley 41 on the counter-shaft, then down around pulley 27, to which disk 28 is attached, thence back over idler 42 on said counter-shaft and down again in a loop around pulley 40, made fast to shaft 29. This arrangement has the advantage of bringing the counter-shaft parallel with the lathe-spindle.

It is obvious that to secure to the lathe-spindle a uniform increase of speed as the tool approaches the center line of the lathe the friction-wheel 23 must be moved toward the circumference of the disks 28 and 28' at an increasing rate as compared with the motion of the tool toward the center. For instance, suppose the friction-wheel 23 were set three inches from the center of the disks to work material eight inches in diameter; when the material had been reduced to four inches the speed should be doubled, to obtain which the friction-wheel must be at a point six inches from the center of the disks; but a further reduction from four to two inches should double the speed again, which would require a movement of the friction-wheel to a point twelve inches from the center of the

disks or a motion of six inches for one-half the movement of the tool-carriage, which in the first case required only a change of three inches in the friction-wheel. This is provided for by the pitch of the cam-groove in the cam 13, which is spiral with a gaining twist. In the arrangement shown in Figs. 1, 2, 3, and 4, when the rack and pinion are used instead of the cam-groove and stud, an eccentric-gear or other obvious means might be used to accomplish this result; but I prefer the arrangement shown in Figs. 5 to 10 for this part of the mechanism.

In operating my device I place the driving-wheel 23 as near the center of the driving-disks 28 and 28' as will give the proper rotary speed to the material being cut at its largest diameter, and as the tool advances toward the center thereof the connecting devices draw the friction-driving wheel proportionately toward the outer edge of the driving-disks, thereby increasing the rotary speed of the mandrel and hence of the material being acted upon, and maintaining substantially the same cutting-speed of the material against the tool from the largest to the smallest diameter of the piece being cut.

I do not limit my invention to the use of the disks and friction-wheel as a means of producing a variable motion to the mandrel, as it is obvious that various equivalent devices might be used, and also other means of connecting the cross-feed of the tool-post with the devices used for varying the speed of the mandrel might be used, without going beyond my invention, as I believe I am the first to automatically connect the cross-feed of a tool-carriage with a speed-varying apparatus attached to the mandrel of a lathe, so that the speed of the mandrel shall increase as the tool moves inward toward the center line of the lathe, thus maintaining an approximately regular speed of the material being worked against the tool.

I claim—

1. In a lathe, a rotary mandrel, variable-speed driving mechanism, substantially as shown, a tool-carriage movable toward and from the axial line of said mandrel, a cam mounted on a shaft rotated by the movement of said tool-carriage, and mechanism connecting said cam to said driving mechanism, whereby the speed of said mandrel is increased as the tool-carriage is moved toward the axial line of said mandrel, arranged and to operate substantially as herein set forth.

2. In a lathe, a rotary mandrel, variable-speed driving mechanism, substantially as shown, a tool-carriage operated by a cross-feed screw, a cam-shaft geared to said cross-feed screw and carrying a cam that by connecting mechanism substantially as shown affects the said driving mechanism to increase the speed of said mandrel as the tool-carriage is moved toward the axial line of said mandrel, arranged and to operate substantially as set forth.

3. The combination of the mandrel 26, driving-disks 28 and 28', and friction-wheel 23 with the tool-carriage *d* and means whereby said wheel is moved toward the circumference of said disks as the said tool-carriage is moved inward toward the axial line of the mandrel, substantially as set forth.

4. In a lathe, a mandrel, a friction driving-wheel, as 23, geared thereto, disks, as 28 and 28', adapted to drive said wheel at a varying speed according to its distance from the center of said disks, a tool-carriage movable in a plane at right angles to the axial line of said mandrel, and mechanism connecting said tool-carriage and friction-wheel, adapted to move said wheel 23 toward or from the circumference of said disks as the tool-carriage is moved toward or from the axial line of said mandrel, arranged and to operate substantially as specified.

5. In a lathe, the shaft 12, means for connecting it to the cross-feed screw 1 of the tool-carriage *d*, so as to be rotated thereby, the cam 13 on said shaft, upright shaft 16, carrying arm 15, provided with a stud and roll operated by said cam 13, arm 17, connecting-rod 18, shipper-rod and fork 19, shaft 20, carrying friction-wheel 23 and geared to the mandrel 26, and the driving-disks 28 and 28', adapted to be rotated in opposite directions, arranged to operate substantially as described.

6. In a lathe, the combination, with a cross-feed screw, of a horizontal shaft connected thereto with intermediate gearing, a cam upon said shaft, an upright shaft carrying two horizontally-projecting arms, the lower arm carrying a stud operated by said cam to partially rotate the said upright shaft, a horizontal shaft carrying a friction-wheel, said last-mentioned shaft being movable longitudinally in its bearings by a shipper-rod and fork operated by a link connected to the upper arm on said upright shaft and connected by gearing to the mandrel of the lathe, and friction-disks adapted to drive said friction-wheel, substantially as herein specified.

7. In an apparatus for giving a variable motion to a lathe-mandrel, the combination, with a shaft and a friction-disk fastened thereto, of another disk loose upon said shaft, but fast to a driving pulley upon the same shaft, a bevel-gear also loose upon said shaft and fast to said pulley, and another gear fast upon said shaft and connected to said first-

mentioned gear by an intermediate gear, whereby power applied to said pulley causes said friction-disks to revolve in opposite directions, substantially as herein set forth.

8. In a lathe, the cross-feed screw 1, gear 2 thereon, gear 3 and worm 5 on shaft 4, worm-gear 6, shaft 7, gears 9 and 11, connected by intermediate gear 10, shaft 12, cam 13 thereon, upright shaft 16, arm 15, carrying stud and roll 15^a, engaging with cam 13, arm 17 thereon, connecting-link 18, forked shipping-rod 19, shaft 20, sleeve 21, friction-wheel 23, disks 28 and 28' on shaft 29, with mechanism adapted to rotate said disks in opposite directions, gears 24 and 25, and mandrel 26, all arranged and to operate substantially as set forth.

9. In an apparatus for rotating a lathe-mandrel at a varying speed, the combination, with such mandrel, of a rotatable sleeve connected thereto by gears so as to rotate therewith, a shaft movable longitudinally within said sleeve, but so connected thereto as to rotate with it, a friction-wheel mounted on said shaft, friction-disks adapted to be rotated so as to rotate said friction-wheel by contact with its periphery, and means for moving said friction-wheel toward or from the center or centers of said friction-disks and thereby cause its speed of rotation to be diminished or increased accordingly, substantially as herein set forth.

10. In an apparatus for connecting the cross-feed of a lathe with a speed-varying apparatus attached to its mandrel, a shaft at right angles to the axial line of said mandrel, but not in the same plane therewith, two arms projecting from said shaft and fastened thereto, a cam adapted to be rotated by the rotation of the cross-feed screw, said cam being arranged to operate a stud connected to one arm on said shaft so as to partially rotate it, the other arm of said shaft being connected with a friction-wheel, so as to move it along its axial line as said shaft is partially rotated and thus vary its speed, substantially as and for the purpose herein set forth.

In testimony whereof I have signed my name to this specification, in the presence of two subscribing witnesses, on this 29th day of January, A. D. 1891.

EUGENE CHILDS.

Witnesses:

H. STORER BARRY,
WILLIS C. HAMLIN.